

## HISTORICAL ICE-HOUSES: REMARKABLE EXAMPLE OF IRANIAN CULTURAL HERITAGE

Amirkhani ARYAN<sup>a</sup>, Okhovat HANIE<sup>b</sup>, Pourjafar Mohammad REZA<sup>c</sup>, Zamani EHSAN<sup>d</sup>

<sup>a</sup> PhD Student; Department of Architecture, Faculty of Art, University of Tarbiat Modares, Jalal Ale Ahmad St, Tehran, Iran  
E-mail: *Aryan\_Amirkhani@modares.ac.ir*

<sup>b</sup> PhD Student; Department of Architecture, Faculty of Art, University of Tarbiat Modares, Jalal Ale Ahmad St, Tehran, Iran

<sup>c</sup> Associate Prof.; Department of Architecture, Faculty of Art, University of Tarbiat Modares, Jalal Ale Ahmad St, Tehran, Iran

<sup>d</sup> Msc.; Department of Architecture, Faculty of Art, University of Tarbiat Modares, Jalal Ale Ahmad St, Tehran, Iran

Received: 28.09.2009; Revised: 08.10.2009; Accepted: 4.12.2009

### Abstract

Iranian vernacular architecture has developed over millennia in response to the Iranian plateau's arid climate, scarcity of acceptable building stone and wood, and extremes of temperature. The ubiquitous building material is sun-dried brick and rammed earth. Building types include wind towers which exhaust warm air from buildings during the day, cisterns which are egg-shaped in section; Icehouses with walls behind which water in shallow channels freezes at night, etc.

Herein, the great Iranian tradition is as yet little known in the West and there is much to be learnt both from it and the building techniques which are integral with it. Meanwhile, not only is the Iranian vernacular building tradition itself still alive, but there is much to be gained from the knowledge of a highly developed technology which makes such ingenious use of natural resources without the consumption of additional power. Among different Iranian cultural heritage constructions, Icehouses are the subject of the main body of this article.

### Streszczenie

Irańska narodowa architektura rozwijała się przez tysiąclecia na irańskim płaskowyżu w warunkach suchego klimatu, w skrajnościach temperaturowych, przy brakach zadowalającego do budowy kamienia budowlanego i drewna. Wszelkimi materiałem budowlanym była wysuszona na słońcu cegła i ubita ziemia. Typami budynków zawierającymi wiatrowe wieże i wyciągającymi ciepłe powietrze z budynków podczas dnia są zbiorniki o jajowatym przekroju; budynki do przechowywania lodu ze ścianami, za którymi zamarza w nocy woda w płytkich kanałach, etc.

Wielka irańska tradycja jak dotąd jest mało znana na Zachodzie i można się wiele od niej nauczyć, zarówno z niej samej jak i techniki budowania, z którą jest zintegrowana. Tymczasem, nie tylko irańska narodowa tradycja budowania jest nadal żywa i aktualna, ale jest w niej wiele wiedzy z której może skorzystać wysoce rozwinięta technologia, wzbogacając się o pomysłowe wykorzystanie surowców naturalnych bez konsumpcji dodatkowej energii.

Pośród różnych tradycyjnych konstrukcji dziedzictwa kulturowego Iranu, za podstawę niniejszego artykułu wybrano problematykę budynków do przechowywania lodu.

Keywords: Iran; Vernacular Architecture; Cultural Heritage; Ice-Houses.

## 1. INTRODUCTION

Iran's traditional architecture is designed in proportion to its climatic conditions, and more than often, the unique fabled artistic background of Persia makes up for the seemingly lack of natural resources and

beauty. Some years ago, a huge legacy of fascinating and often beautiful vernacular buildings survived on the Iranian Plateau. Many occurred chiefly in the villages, but others had their grander counterparts in the towns. Some are either unique to Iran or may be prototypes of buildings elsewhere. Few Iranians or visitors

have had time or inclination to look at such buildings, partly because the huge number which survived has tended to make them commonplace, but also because Iran has such a wealth of architectural and artistic treasure which has demanded prior attention.

However, unless positive action is taken, most will have crumbled. Their rapid disappearance derives from a variety of good reasons. A redundant building, constructed of stone in a temperate climate, may survive many years as a ruin. [1] But these Iranian buildings are chiefly built of unbaked mud-brick. Any mud-brick building quickly deteriorates without constant maintenance; this inevitably ceases once a building is no longer useful. The fierce climate of the Plateau accelerates this process! [2] Technological innovations of the first half of this century are the root cause of their redundancy.

Modern refrigeration, new sources of power and the internal combustion engine have overtaken such buildings as ice-houses, mills and caravanserais. Landlord's houses and buildings such as hunting lodges have been neglected, both on account of absenteeism and also of land-reform. [3]

Readers may notice that the literary sources referred to in this paper are confined in range. Few travelers, either today or in the past, have been sufficiently interested to record cultural heritage buildings. Those that have (notably John Fryer in the seventeenth century, C. J. Wills in the nineteenth and Hans E. Wulff in the twentieth) have shown a general interest in both Persian buildings and customs which is rare.

The notes which follow are the result of researches since 2007. During this time examples of the following types of buildings were noted, some briefly. They are listed here in the hope (justified by experience) that others, may have information to contribute (which would be much appreciated): ice-houses, cisterns, water mills, wind-catchers, windmills, animal mills, houses, hunting-lodges, agricultural buildings, pigeon towers and caravanserais. Herein, Icehouses are the subject of the main body of this paper. These buildings combine skills in which the Iranians excel. Skills like the Persian imagination and ingenuity, which are unrivalled in making the best use of water in a hostile desert environment. In this the Iranian contribution to the world's technology is probably unique.

## 2. ICEHOUSES

Icehouses were buildings used to store ice throughout the year, prior to the invention of the refrigerator. The most common designs involved underground

chambers, usually man-made, which were built close to natural sources of winter ice such as freshwater lakes. During the winter, ice and snow would be taken into the Icehouse and packed with insulation, often straw or sawdust. It would remain frozen for many months, often until the following winter, and could be used as a source of ice during summer months. This could be used simply to cool drinks, or allow ice-cream and sorbet desserts to be prepared. The common use by the Persians of ice and snow for cooling drinks and food was reported by John Fryer in the late seventeenth century: "They mightily covet cool things to the Palate. Wherefore they mix snow, or dissolve ice in their Water, Wine or Sherbets," [4] he wrote (and of Isfahan), "... the Poor, have they but a Penny in the World, the one half will go for Bread, and dried Grapes, and the other for Snow and Tobacco...". Outside Shiraz he saw that ice was stored in "Repositories" which he tantalizingly describes only as "fine buildings" [5] but it seems likely that they were similar to the huge domed structures still to be seen in parts of Iran. Only a few survive, most as disintegrating ruins, although they were in common use only a few years ago. By Fryer's time the practice of storing ice was probably already long established, possibly having been introduced by the Mongols. (Icehouses in China were known as early as the eighth century B.C.; they were probably small thatched buildings, like their successors there.)

In Britain, ice was not then considered to be a common necessity and was certainly not for the poor, but the Icehouse was to become a feature of the great eighteenth-century estate, as it was in France. However, the English Icehouse is as a bantam's egg to an eagle's when compared with those of the Iranian Plateau. There the great demand led to buildings of monumental scale and size. Fig. 1 shows the Stourhead Icehouse, [6] one of the larger English examples, drawn to the same scale as a typical Iranian Icehouse at Yazd. [7] However, the principles governing the design of each are the same: the ice has to be insulated and kept dry. The differing climates made insulation a far greater problem in Iran, and drainage of prime importance in damp, temperate Britain.

Obtaining the ice was another matter. Iran is not only largely desert, but fresh water is rare and even in winter, when the temperature falls to freezing at night, the mid-day sun is hot. Huge quantities of ice would be needed to fill these vast, domed wells. Some was brought as blocks of snow from the mountains, but the ingenious Persians, ever inventive in their mas-

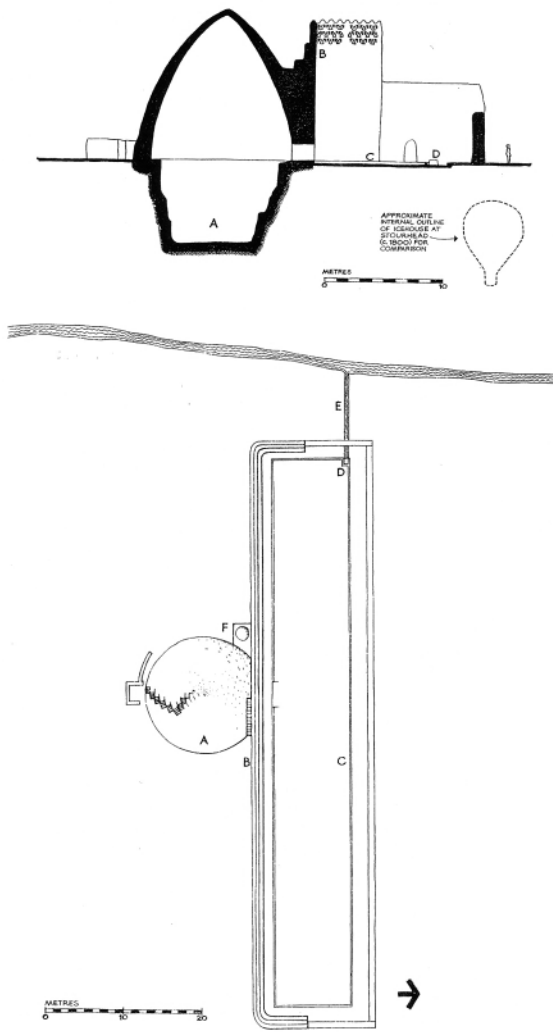

Figure 1. Icehouse at Yazd: Plan and section. [Author]

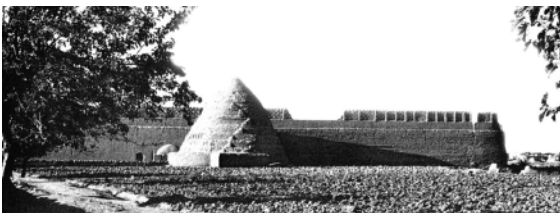

Figure 2. Icehouse and shade wall near Yazd. [The image archive of Tarbiat Modares University]



Figure 3. A and B: Remains of the Icehouses near Kashan. [Author]



Figure 4. Remains of the Icehouses with shade walls near Sabz-e-Var. [Author]

terly adaptation of desert conditions, had an imaginative and simple answer. Alongside each Icehouse is a long shallow channel, about 100×10 m and 40-50 cm deep, which is entirely shaded by a great wall, longer than the pool and as much as 12 m high; the wall is constructed of rammed earth and mud-bricks made from the earth which was excavated to

form the channel. The channel is lined with tiles to make it watertight. C. J. Wills gives a clear description of ice-making in the latter part of the nineteenth century: “The delicious AB-I-ROOKHI (stream of Rookhnabad) is diverted from its course on the first cold night. A few inches of still clear water is collect-

ed in the pond, by morning it is frozen, at night the water is collected in the pond, by morning it is frozen, at night the water is again admitted and another inch or two of ice is made. [8] When three to six inches thick the ice is broken and collected for storage in a deep well on the spot; and so day by day the process goes on during the short winter, until the warehouses are full. Should the supplies from these be exhausted by a very large demand, ice, or rather blocks of snow, are brought from the mountains; but as these are some distance, and snow melts faster than ice, the weights being equal, the price rises." [9] The ones who remember the work in ice-houses say that on clear frosty nights water would be diverted from a stream to the ice pool. The ice formed was usually skimmed off in layers of about one inch. It was packed hard down, each layer insulated by straw (and presumably rammed as in Britain). Then the door was sealed and the ice kept until it was needed in summer. The man in charge of the Icehouse would probably be responsible for the cistern in the village and might also look after the mosque. Villagers would be asked to contribute towards his wage and the repairs of the Icehouse.

The low cost of the ice and the way it was used was also explained by Wills. "The great thing in such a place is the cheapness of ice, for about 15s in dear years and 5s. in cheap ones, ice can be obtained all through the warm weather, and in fact is used from May to October, as no one would think of drinking anything uncooled. A huge block is thrown down each morning by the ice seller-it is supposed to weigh 14 lbs." The Icehouse is best understood from the illustrations. Barely half-a-dozen have been seen, although hundreds must have been in use even sixty years ago, particularly in the vicinity of rich cities on the edge of the desert, like Yazd or Kashan, and on caravan routes like the one in Sabz-e-var.(Figs 2, 3a-b and 4) Those measured ranged from 9 to 14 m in internal diameter. The overall internal height of that at Yazd is c. 19 m. The disused Icehouses had often been used as rubbish dumps so it was not possible to investigate the method of drainage (if any). One or two had boldly decorated walls, the bricks near the top being laid in open checkered patterns and the tops crenellated. Most spectacular perhaps was the pair of Icehouses found on the outskirts of Sirjan; the ice-walls which linked them curved to give extra shade, giving a plan form like some huge winged creature (Fig. 5).

Although a mass of nineteenth century literature is available on English Icehouse construction, notably in

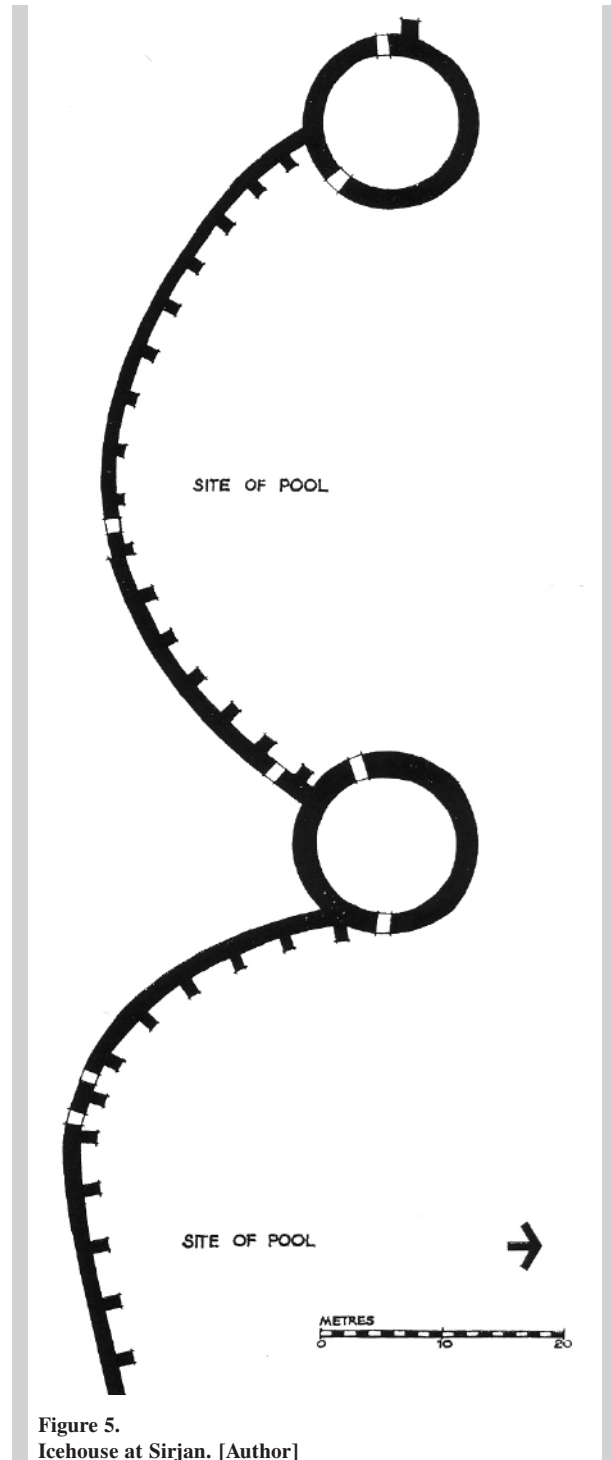
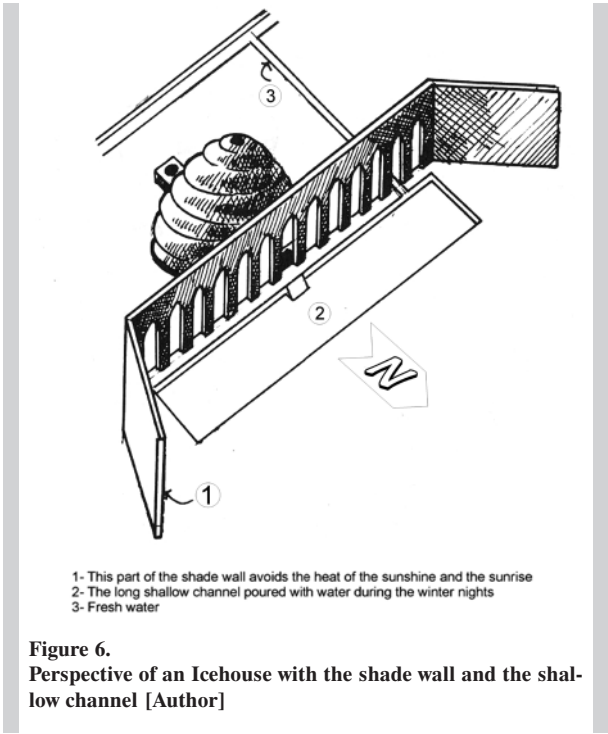

Figure 5.  
Icehouse at Sirjan. [Author]

garden encyclopedias such as Loudon's, or in books like Pap worth's Rural Residences, almost nothing seems to have been written on examples outside Europe. The notable exception is the redoubtable Mrs. Fanny Parkes, whose Wanderings of a Pilgrim in Search of the Picturesque gives a vivid account of life





in India in the second quarter of the nineteenth century. She describes the ice-pits of Allahabad: “My husband has the management of the ice concern this year. It is now in full work, the weather bitterly cold, and we are making ice by evaporation every night.” At first glance, the principle might be thought to be similar to the Iranian method, the word “evaporation” perhaps having crept in unnecessarily. But such assumptions are shown to be wide of the mark by the unexpected statement of this careful author: “The highest temperature at which ice was made in 1846 at Cawn pore was 430 of Fahrenheit or 110 above freezing point”. [10] Her drawing shows that the ice was not made in the channel as in Iran. Instead, the channel or pit, which was a cubit deep, was filled with dry straw; small bowls were placed on it which were filled from pitchers and the ice was made in these. Presumably the bowls were porous; evaporation would lower the temperature of the water and the dry straw would insulate the bowls from the heat radiated from the ground-on a still clear night the temperature of the water could be several degrees lower than that of the air immediately above the surrounding ground. Even so, this explains nothing fully, and it would be interesting if any reader could provide a complete answer. Mrs. Parkes reported that her husband’s work went on until February 19<sup>th</sup>, by which time over 107 tons of ice had been made. It was stored in small thatched buildings similar to those used in China. This single Indian

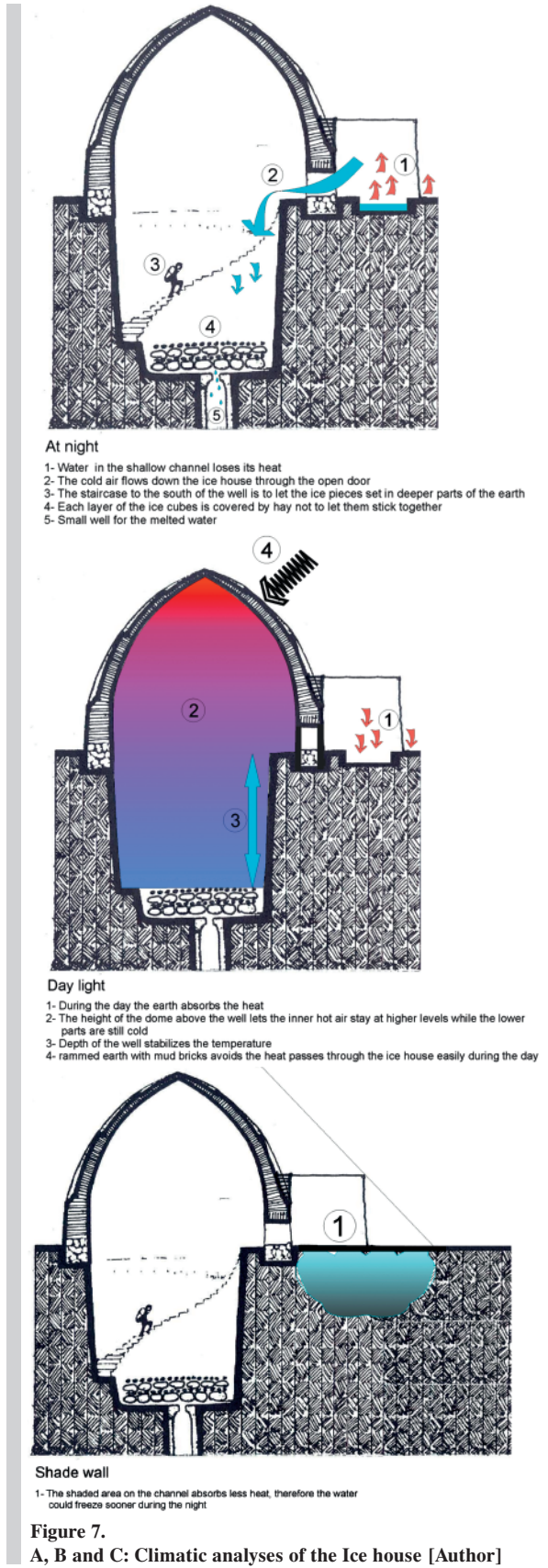

example makes one wonder whether there is not more to be learnt about Persian techniques than might at first be imagined. Although modern methods of refrigeration have made the Icehouse obsolete in Persia, there are still people who can remember its use.

### 3. HOW THE BUILDING WORKS

The long shallow channel to the north of the shade walls is poured with water during the winter nights, when the weather is very cold in Iranian desert. As the temperature of the earth and the water is higher than the sky during the night hours, the water will lose its heat and can easily freeze till next morning. The amount of water in the shallow channel depends mostly on the clouds. If the weather is very cloudy, the depth of the water in channel would be small so that it can freeze easier. (Clouds act as an isolation layer for the exchange of cold and heat) (Fig. 6).

Before the sun rises, the ice made in channels is crashed into pieces as the smaller pieces lose heat faster than the bigger ones. They are moved to the vast domed wells afterwards. The depth of the wells stabilizes the temperature. So during the day, the changes of temperature would not affect the ice pieces. On the other hand, the height of the dome above the well lets the inner hot air stay at higher levels during the day while the lower parts are still cold.

The material used to construct the building is from rammed earth with mud bricks which avoids the heat passing through the Icehouse easily during the day. Meanwhile it is made of the earth which was excavated to form the channel. So it is beneficial too.

High mud brick walls to the north of the domes are used to spread a vast shaded area on the channel during the day. So it prevents the earth on the channel area from absorbing the heat as much as in the other parts. Therefore, the water could freeze sooner during the night.

Here are diagrams analyzing the flow of hot and cold air in the building. (Fig. 7 a-c)

### 3. CONCLUSION

The intermediate technology is now seen by many to be an essential ingredient of progress in the 21<sup>st</sup> century. [11] This great Iranian tradition is as yet little known in the West and there is much to be learnt both from it and the building techniques which are integral with it. It is the fate of vernacular buildings throughout the world to be neglected until they are

nearly extinct. The Folk Museum and the Museum of Buildings are relatively new ideas in Europe, where they are thought of primarily in terms of conservation and education in history and the arts. In Iran their value could be even greater since these functions could be combined with those of an institute of intermediate technology. Not only is the building tradition itself still alive, but there is much to be gained from the knowledge of a highly developed technology which makes such ingenious use of natural resources without the consumption of additional power. The Persian Icehouse with its great shade wall could hardly be described as small, but the technology it represents is certainly beautiful in its simplicity. [12] However, unless positive action is taken, most Iranian cultural heritage buildings will have crumbled. Thus, in the name of Iranian architectural heritage, it is hoped that any further decay of such historical constructions can be prevented by funding.

### REFERENCES

- [1] *Kasmaie M*; Climate and Architecture, published by the Iranian Construction-Co, Tehran, 1984, p.54-8
- [2] *Stronach, D. B.*, The first international colloquy on the conservation of mud brick monuments, published by ICOMOS, Yazd, 1973, p.64-73
- [3] *Hyde R.*; Climatic Responsive Design, E & FN SPON publications, New York, 2000, p.97-112
- [4] *Fryer J.*; A new account of the east Indies and Persia being nine years travels 1672-81, Vol.3, published by Cultural research association, Tehran, 1963, p.149
- [5] *Ibid.*, Vol.2, pp.218-48, 168
- [6] *Locke G.*; Icehouse, National trust newsletter 24, (1975), p.20
- [7] Yazd the Gem of the Desert, a tourist information guidebook, Vol. 1, Published by: The society of Yazd Public Libraries, Yazd, 1997, p.75-84
- [8] *Tavassoli M.*; Architecture of hot arid climate, published by Tehran University, Tehran, 1974, p.38
- [9] *Wills C.*; The land of the lion and the sun (Modern Persia), being experienced of life in Persia from 1866-81, published by Broadway travelers' edition, London, 1891, p.241
- [10] *Parkers F.*; Wanderings of a pilgrim in search of the picturesque, Vol.1, Published by Hutchinson, & Ross, Inc, London, 1852, p.78-83
- [11] *Murakami, Shuzo*; Environmental assessment of vernacular architecture, published by keio university press, Keio, 2008, p.67
- [12] *Ghobadian V.*; Climatic Analysis of the Iranian Traditional Buildings, Tehran University Publications, Tehran, 1998, p.308-37